

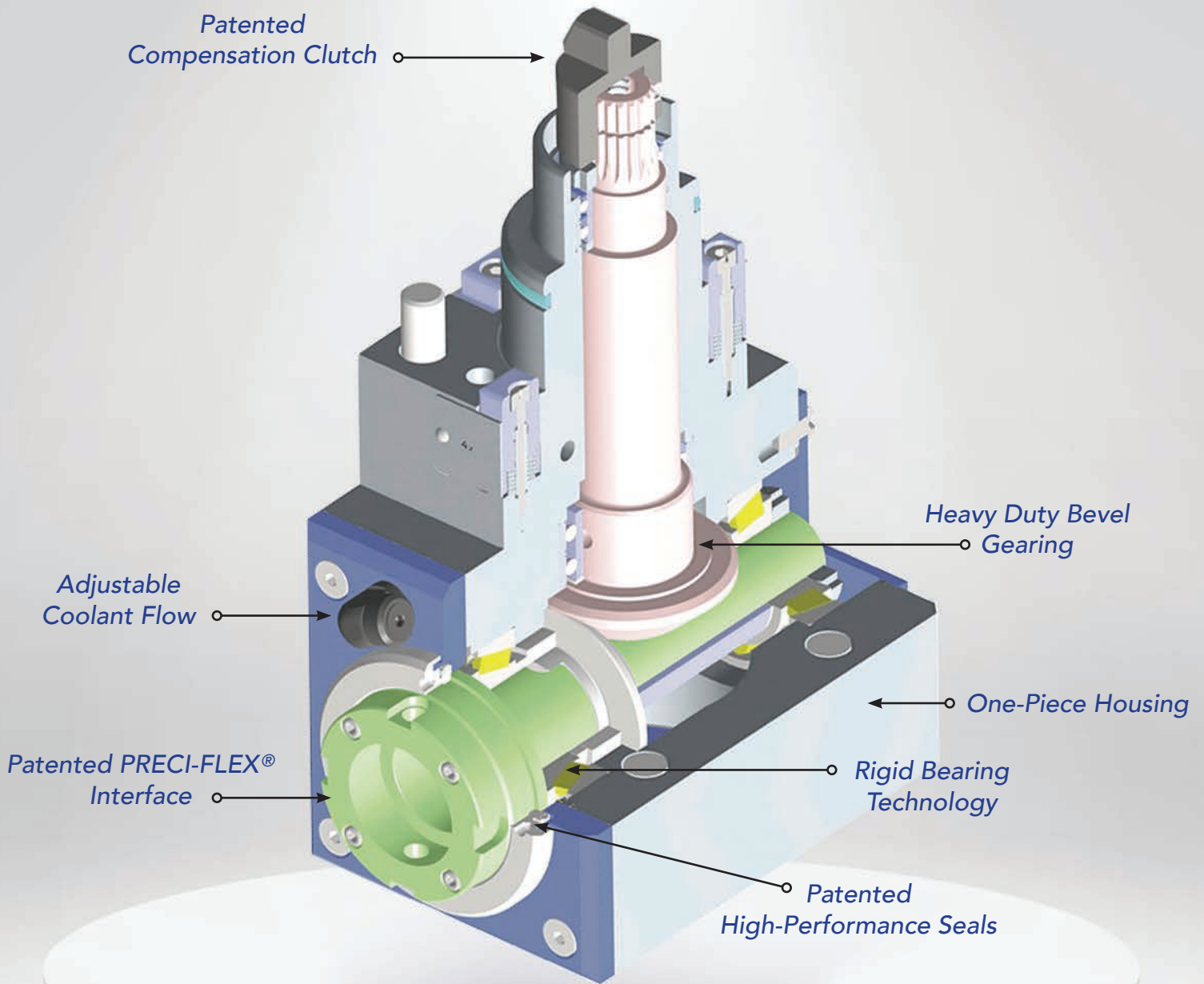

COMPLETE TOOLING SYSTEMS FOR CNC TURNING CENTERS



OVERVIEW OF EPPINGER DRIVEN TOOLS INNOVATIVE TECHNOLOGIES



INNOVATIVE DESIGNS: COMPENSATION CLUTCH

ISSUE:

The centerline of the turret mill drive is often slightly misaligned with the centerline of the tool holder creating excessive vibration during operation.

- **Lost Time and Productivity** – Premature wear on the tool holder drive assembly results in more frequent maintenance service.
- **Increased Maintenance Costs** – More expensive and longer maintenance service is required as more drive components need to be replaced.
- **Reduced Cutting Tool Life** – Increased vibration reduces cutting tool life drive up cutting tool costs.
- **Reduced Tool Holder Capabilities** – Misalignment between the turret mill drive and the tool holder drive tang reduces contact area between these critical components resulting in less torque transmission that limits the capabilities of the tool holder.

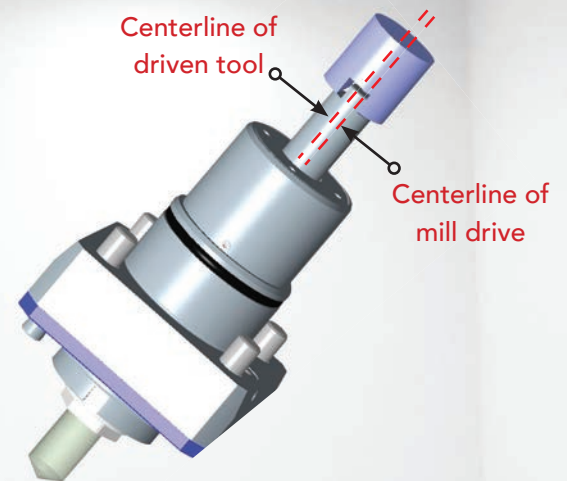

SOLUTION:

Eppinger's patented Compensation Clutch technology automatically adjusts for misalignment between the turret mill drive and the tool holder drive tang dampening vibration.

- **Improves Productivity** – Longer maintenance service intervals keep the tool holder in the machine instead of in the repair department.
- **Reduces Maintenance Service Costs** – Fewer components need replacing during maintenance service, reducing service costs and shortening repair turn-around times.
- **Improves Cutting Tool Life** – Less chatter results in longer tool life and reduced cutting tool costs.
- **Increased Tool Holder Capabilities** – Contact between the turret mill drive and the tool holder drive tang is increased up to 60% providing for greater torque transmission that allows the tool holder to perform more operations.

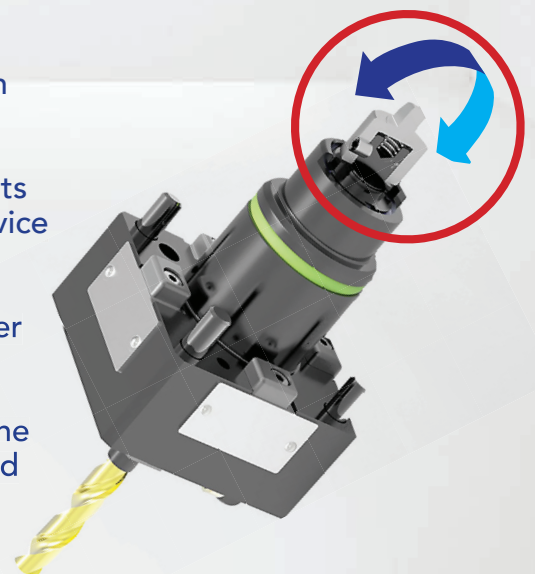

INNOVATIVE DESIGNS: PRECI-FLEX® MODULAR TOOLING SYSTEM

EXPAND THE CAPABILITIES AND EFFICIENCY OF YOUR DRIVEN TOOLS

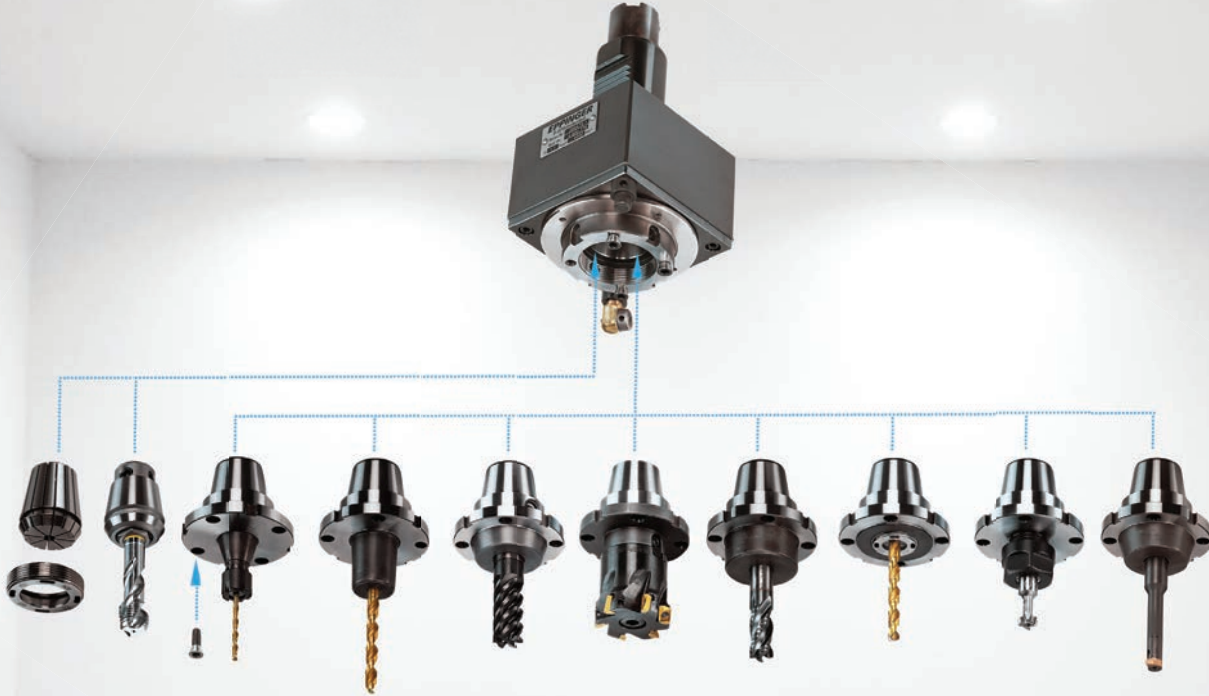

Eppinger Driven Tools come standard enabled to utilize our exclusive Preci-Flex Modular Tooling System.

- **One Tool Holder, Many Tooling Options** – Modular tool outputs include collet, collet chuck, shrink fit, side-lock, face mill holder, stubby, and mini-nut, and allow for a greater range of machining operations.
- **Improves Rigidity** – Minimal projection increases rigidity to improve cutting tool performance and tool life.
- **Improves Productivity** – Preci-Flex adapters can be preset offline, and adapters can be changed quickly with the holder still in the turret increasing machine up-time.

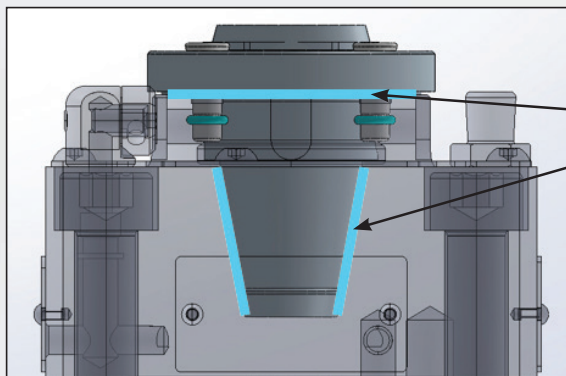

**TAPER & FACE CONTACT
INCREASES RIGIDITY**

- **Saves Time and Money** - Greater rigidity allows for more aggressive machining operations and higher metal removal rates.

INNOVATIVE DESIGNS: **TAPERED ROLLER BEARINGS**

THE COMPETITION

ANGULAR CONTACT BEARINGS

Angular Contact Bearings – Most commonly used spindle bearings because of ease of assembly.

ISSUES:

Reduced Tool Holder Capabilities – Limited contact between rolling elements and race decrease side load capacity reducing the types of operations the tool holder can perform.

Increased Service Costs and Decreased Productivity – Angular bearings are more prone to wear from side-loads requiring more frequent maintenance service and more frequent replacement.

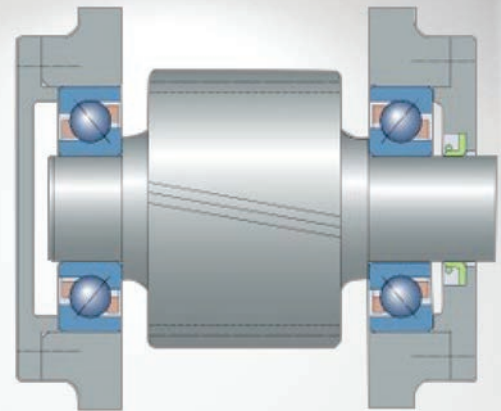

EPPINGER

TAPERED ROLLER BEARINGS

Come standard in all Eppinger driven tools

SOLUTION:

Expanded Tool Holder Capabilities – Greater contact between the rolling elements and the race increases rigidity and side-load capacity allowing for more machining operations and higher metal removal rates.

Reduced Costs and Improved Productivity – More robust tapered roller bearings are not prone to accelerated wear as are angular contact bearings resulting in longer maintenance service intervals and less frequent replacement.

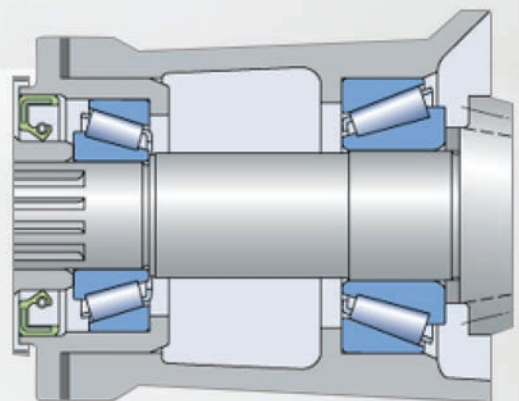

INNOVATIVE DESIGNS: 4-KEY PRESET ALIGNMENT

ISSUE:

Aligning the tool holder in a BMT tool station takes too much time.

- **Lost Productivity** – Potential machining time is lost due to the need to align the tool.
- **Increased Cutting Tool Costs** – Improperly aligned tooling reduces cutting tool life increasing costs.
- **Increased Scrap Costs** - Improperly aligned tooling creates tolerance issues that may require time-consuming and expensive secondary operations or increased scrap rates.

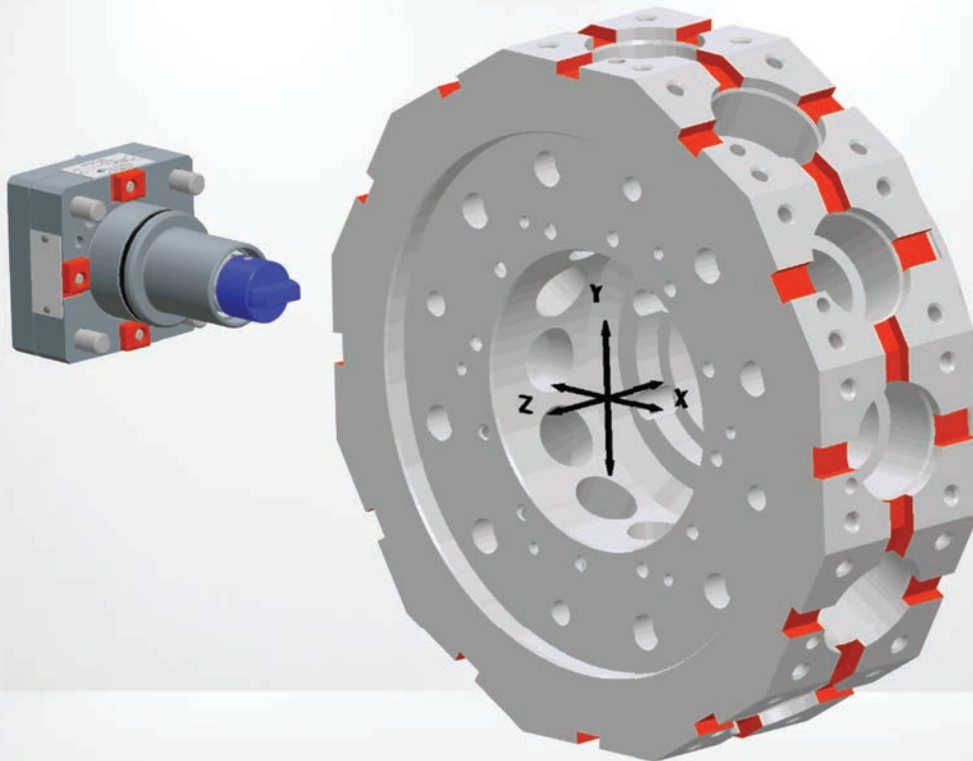

SOLUTION:

Eppinger's patented 4-key preset alignment technology ensures correct alignment.

- **Improves Productivity** – Properly aligning tool holders takes only seconds.
- **Reduces Costs** – Properly aligned tool holders increase cutting tool life and reduce rework or scrap costs due to tolerance issues.
- **Improves Accuracy**
 1. **Positioning repeatability < 0.005mm**
 2. **Alignment to machine < 0.010mm**

EPPINGER TOOL REPAIR SERVICES

EPPINGER USA, an Eppinger Technologies company, is the **ONLY** company in North America providing factory authorized service on Eppinger Driven Tools using 100% genuine OEM parts.

Our factory-trained technicians restore your driven tool to 'like-new' performance parameters.

Our Indianapolis-based repair department appreciates that production time is money, so we turn around the service on your driven tools **FAST!**

Our service department can repair virtually any make and model of driven tools.

Service evaluation is free-of-charge and you are provided a quote prior to any service work being performed.

**ALL  EPPINGER
TOOL REPAIR SERVICE IS
BACKED BY A BEST-IN-CLASS
1-YEAR WARRANTY.**



ONLINE TOOL CONFIGURATOR

Everything you need to find the right tool at your fingertips!

The screenshot shows the EPPINGER website's online tool configurator. At the top right is the EPPINGER logo. On the left, there is a search bar labeled 'Search by Part Number' and a 'Quick Search' section with dropdown menus for 'Manufacturer' (All), 'Model' (All), and 'Werkzeughalter' (All). Below these is a '4653 Products' count and a 'Complete Offering' button. In the center, there is a link 'Click here and discover the right EPPINGER product' and four product categories: 'FIXED TOOL HOLDER', 'ROTARY TOOL HOLDER', 'PRECIFLEX', and 'DECOFLEX'. On the right, there is a 'Search Help For Tool Holder' section with a numbered navigation bar (1, 2, 3) and a 'Contact' section with the following information: EPPINGER USA, 9930 E 56th St, Indianapolis, IN 46236; 800-397-9748 Toll Free Phone, 800-397-9739 Toll Free Fax, 352-588-4345 Phone, 352-588-4821 Fax; RFQ@eppinger.com, www.eppinger.com. At the bottom right, there is a 'Shopping List' section indicating 'Shopping List is Empty'.

Finding the right tool has never been easier!

1. Visit: www.eppinger.com and go to our online catalog.
2. Search by part number directly, or find your machine make and model to view all available tooling.
3. Access tech specs, datasheets, simulation models and more.

WANT SOME ADDITIONAL INFORMATION?

Please send all maintenance service holders to:

EPPINGER USA
9930 E. 56th St.
Indianapolis, IN, 46236
RMA : (Please Reference)

Contact us today!

For service: repair@eppinger.com

For sales: RFQ@eppinger.com

or call **800-397-9748**

For RMA line, put RMA# :

(Please contact us before sending)

EPPINGER

TECHNOLOGIES

Home of

